

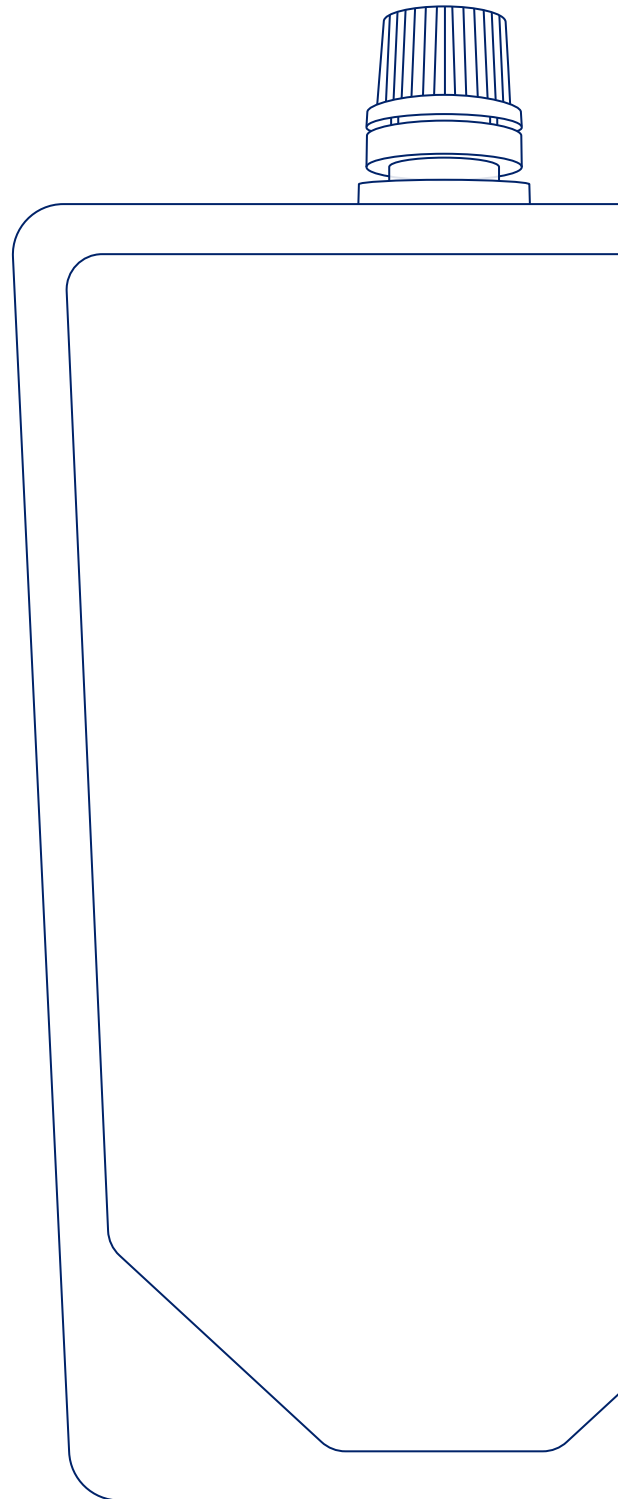

PRE-MADE SPOUTED
POUCH FILLING
AND CAPPING
MACHINE

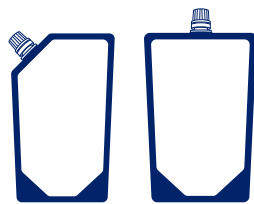

袋式自動充填鎖蓋機



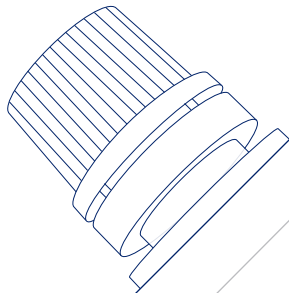

PRE-MADE SPOUTED POUCH FILLING AND CAPPING MACHINE

Fill and cap spout pouches of liquid product automatically. This spouted pouch filling machine is specially designed to incorporate a pre-made top or corner spout pouch, filling through the spout for liquid products. Suitable for food and chemical industry.

Features

- Pouch volume: 100 ml ~ 300 ml
- Capacity: up to 40 pcs/minute
- Pouch dimension: W. 100 x H. 165 mm
- Stainless steel construction
- PLC control with touch screen
- Rail infeed for loading pouches
- Filling system: piston pump via servo control
- Capping head is driven by servo motor
- Compact design to access and maintain easily
- Air consumption: 80 L/min
- Power consumption: 5 kW

袋式自動充填鎖蓋機

噴嘴袋液體自動充填鎖蓋機，用於已成型的噴嘴袋，吸嘴袋充填機專門設計應用於頂部或斜角的噴嘴，透過噴嘴將液體灌裝到袋子，適用於食品和化工產業。

特性

- 充填範圍：100 ml~300 ml
- 產能：40 個 / 每分鐘
- 袋子尺寸：W. 100 x H. 165 mm
- 機台主要結構為不銹鋼
- PLC 控制系統，搭配人機顯示介面，容易操作各設定值
- 軌道式自動入袋裝置
- 容量式充填：定量缸搭配伺服馬達控制
- 鎖蓋頭為伺服馬達控制，可調整扭力
- 簡潔機台設計，容易清潔和保養
- 空氣消耗量：80 L/min
- 動力消耗量：5 kW



Video

KWT®

PFC Series

**PRE-MADE SPOUTED POUCH
FILLING AND CAPPING MACHINE**

袋式自動充填鎖蓋機

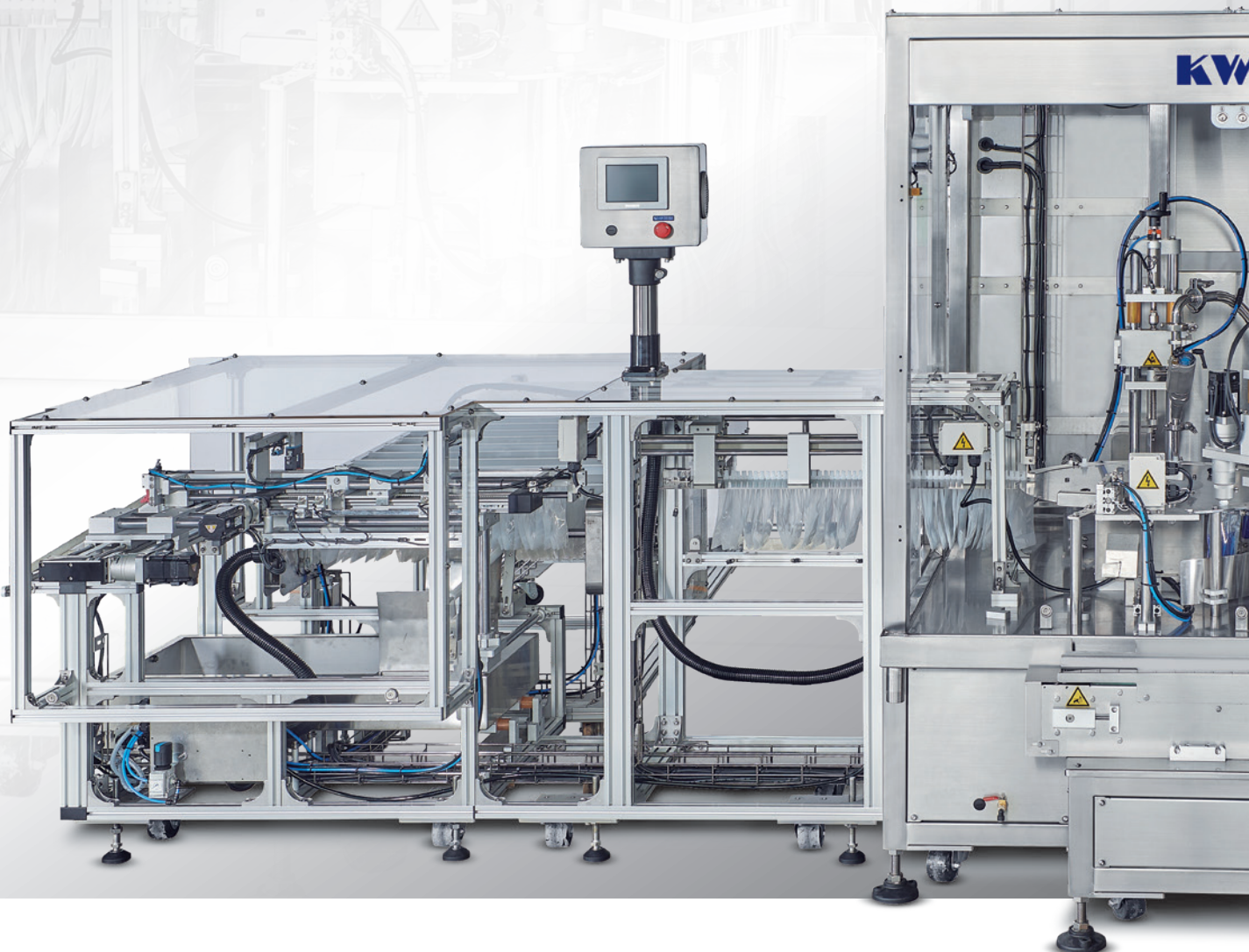

OPERATION PROCEDURE

運作流程

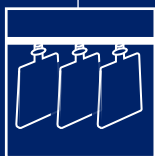

+



+



+



Spout Pouch Infeed

Multiple rows of pre-made spouted pouches are loaded on rails, then transport pouches into the feeding system and insert into the rotary star-wheel.

自動進袋裝置

多軌式置袋軌道，將袋子自動傳送至入袋機構，同時，會將吊桿推入到集料槽

Filling Station

filling nozzle dose inside the neck of spout and seal tightly to ensure that the pouch expansion during filling. Volumetric filling system by piston pump, fills one pouches at a time.

充填區域

透過吸嘴將液體充填至袋子，充填管下降至噴嘴內，防止液體噴濺。採用定量缸充填，並搭配伺服馬達控制，適用於高低黏稠度的液體，準確的劑量灌裝

Capping Station

A vibratory bowl feed caps to the cap chute and place caps on the spout accurately, then the capping chuck tighten caps by means of servo motor, torque is adjustable through touch screen.

鎖蓋區域

選蓋方式採用振動桶，將蓋子送至下蓋軌道，並確實的將蓋子放置到噴嘴上，然後再透過鎖蓋裝置將蓋子鎖緊，鎖蓋頭為伺服馬達控制，可調整鎖蓋扭力

Pouch Discharge Station

Pouches are discharged on a chute for delivery.

成品出袋區域

充填鎖蓋完後的袋子會滑落至出料軌道



Machine Dimensions

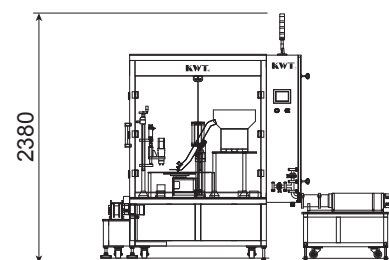
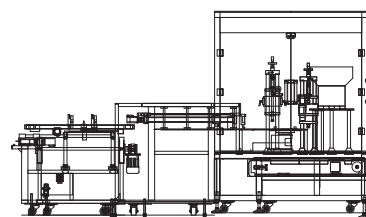
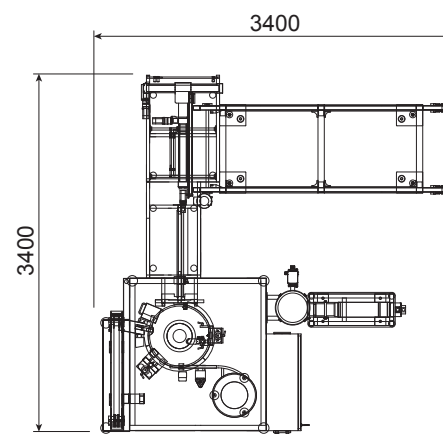

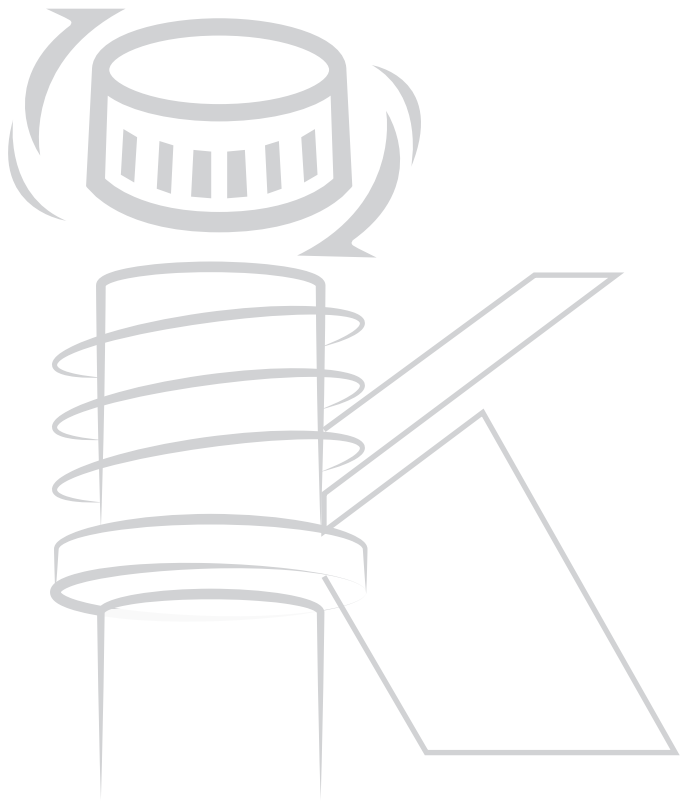

KWT[®]

KWT MACHINE SYSTEMS CO., LTD.

克維特有限公司

T +886-4-2277-3390

F +886-4-2277-3412

www.kwt-auto.com

sales@kwt.com.tw

No.21, Taiping 21 Street, Taiping
Dist., Taichung City 411021, Taiwan.

411021 台中市太平區太平 21 街 21 號

